

# Experimental Studies with Continually Online Trained Artificial Neural Network Identifiers for Multiple Turbogenerators on the Electric Power Grid

<sup>1,2,4</sup>G K Venayagamoorthy, *Member, IEEE*, <sup>3,4</sup>R G Harley *Fellow, IEEE* and <sup>1</sup>D C Wunsch, *Senior Member, IEEE*

<sup>1</sup>*Applied Computational Intelligence Laboratory, University of Missouri-Rolla, MO 6409 0040, USA*

<sup>2</sup>*Department of Electronic Engineering, M L Sultan Technikon, P O Box 1334, Durban 4000, South Africa*

<sup>3</sup>*School of Electrical and Computer Engineering, Atlanta, GA 30332-0250, USA*

<sup>4</sup>*School of Electrical and Electronic Engineering, University of Natal, Durban 4041, South Africa*  
gkumar@ieee.org, ron.harley@ece.gatech.edu & dwunsch@ece.umn.edu

## Abstract

*The increasing complexity of a modern power grid highlights the need for advanced system identification techniques for effective control of power systems. This paper provides a new method for nonlinear identification of turbogenerators in a 3-machine 6-bus power system using online trained feedforward neural networks. Each turbogenerator in the power system is equipped with a neuroidentifier, which is able to identify its particular turbogenerator and the rest of the network to which it is connected from moment to moment, based on only local measurements. Each neuroidentifier can then be used in the design of a nonlinear neurocontroller for each turbogenerator in such a multimachine power system. Experimental results for the neuroidentifiers are presented to prove the validity of the concept.*

## 1 Introduction

Power systems are increasingly called upon to transmit more power due to economic considerations and therefore the need for advanced system identification techniques for effective control of multimachine power system. Synchronous turbogenerators supply most of the electrical energy produced by mankind and are largely responsible for maintaining the stability and security of the electrical network. The effective control of these machines is, therefore, important. However, turbogenerators are highly non-linear, time varying, fast acting, Multiple Input Multiple Output (MIMO) machines with a wide range of operating conditions and dynamic characteristics that depend on the entire power system to which each of these is connected [1,2]. Conventional automatic voltage regulators and turbine governors are designed to optimally control each of these turbogenerators

around one operating point; at other operating points each turbogenerator's performance is degraded. Adaptive controllers for turbogenerators can be designed using linear models and traditional techniques of identification, analysis, and synthesis to achieve the desired performance. Often restrictive assumptions are made [3] about the likely disturbances. However, due to the nonlinear time varying nature of a turbogenerator, it cannot be accurately modeled as a linear device.

Moreover, when different turbogenerators with conventional controllers are connected, low frequency oscillations may result. Power System Stabilizers (PSSs) are used to damp such oscillations, but the particular position and transfer function of a PSS is not a simple decision and is usually also based on some linearized system model.

In recent years, renewed interest has been shown in the area of power systems control using nonlinear control theory, particularly to improve system transient stability [4]. Instead of using an approximate linear model, as in the design of the conventional power system stabilizer, nonlinear models are used and nonlinear feedback linearization techniques are employed on the power system models, thereby alleviating the operating point dependent nature of the linear designs. Using nonlinear controllers, power system transient stability can be improved significantly. However, nonlinear controllers have a more complicated structure and are difficult to implement relative to linear controllers. In addition, feedback linearization methods require exact system parameters to cancel the inherent system nonlinearities, and this contributes further to the complexity of stability analysis. The design of decentralized linear controllers to enhance the stability of interconnected nonlinear power systems within the

whole operating region is still a challenging task [5]. However, the use of Neural Networks (NNs) offers a possibility to overcome this problem.

Neural networks are able to identify/ model such time varying single turbogenerator systems [6] and, with continually online training these models can track the dynamics of the turbogenerator system thus yielding adaptive identification. Online NN controllers have been successfully implemented on single turbogenerators using neuroidentifiers [7]. Neuro-identification of turbogenerators in a multimachine power system has been successfully investigated in simulation on a five-machine system [8].

This paper extends previous work [8], to now include the identification of the exciter and turbine dynamics as well, and present results for the real-time implementation of neuroidentifiers for turbogenerators in a 3-machine 6-bus power system in the micro-machines laboratory at the University of Natal, Durban, South Africa.

### 2 Laboratory Power System Being Tested

The micro-machine laboratory at the University of Natal has two micro-alternators, and each one represents the electrical and mechanical aspects of a typical 1000 MW alternator. All the per-unit parameters except the field winding resistance are the same as those normally expected for 1000 MW alternators. The machine parameters were determined by the standard IEEE methods and are given for micro-alternators #1 and #2 in Tables 1 and 2 respectively [9]. Each micro-alternator is equipped with a Time Constant Regulator (TCR) which is used to insert negative resistance in series with the field winding circuit, in order to reduce the actual field winding resistance to the correct per-unit value [9].

Table 1: Micro-alternator #1 parameters

$T_{d0}' = 4.50$ s	$X_d' = 0.205$ pu	$R_s = 0.006$
$T_{d0}'' = 33$ ms	$X_d'' = 0.164$ pu	$H = 5.68$
$T_{q0}'' = 0.25$ s	$X_q = 1.98$ pu	$F = 0$
$X_d = 2.09$ pu	$X_q'' = 0.213$ pu	$p = 2$

Table 2: Micro-alternator #2 parameters

$T_{d0}' = 3.72$ s	$X_d' = 0.205$ pu	$R_s = 0.006$
$T_{d0}'' = 33$ ms	$X_d'' = 0.164$ pu	$H = 5.68$
$T_{q0}'' = 0.25$ s	$X_q = 1.98$ pu	$F = 0$
$X_d = 2.09$ pu	$X_q'' = 0.213$ pu	$p = 2$

A 3-machine 6-bus power system shown in Fig. 1 is set up by using two micro-alternators and the infinite bus (with fixed voltage and fixed frequency) as the third machine. The conventional controllers are excluded for the purposes of system identification carried out in this paper. The switch S1 shown in Fig. 1 is closed to synchronize the two micro-alternators to each other after they separately synchronized to the infinite bus. The switch S2 is used to switch in/out transmission lines and the switch S3 is used to switch in/out a load.

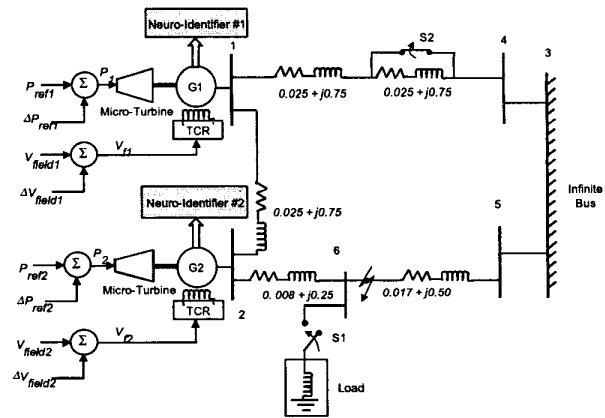

Figure 1: Multimachine power system

### 3 Online Trained Neuroidentifier

The neuroidentifier is developed using the series-parallel Nonlinear Auto Regressive Moving Average (NARMA) model [10]. This model output  $\hat{y}$  at time  $(k+1)$  depends on both past  $n$  values of output and past  $m$  values of input. The neuroidentifier output equation takes the form given by eq. (3).

$$\hat{y}(k+1) = f \left[ \begin{matrix} y(k), y(k-1), \dots, y(k-n+1), \\ u(k), u(k-1), \dots, u(k-m+1) \end{matrix} \right] \quad (3)$$

where  $y(k)$  and  $u(k)$  represent the output and input of the plant at time  $k$  respectively. This model has been chosen in preference to all other system identification models [10] because online learning is desired to correctly identify the dynamics of the turbogenerator and therefore avoiding a feedback loop in the model, which allows static backpropagation to be used to adjust the NN weights. This reduces the computational overhead substantially for online learning.

The neuroidentifier in Fig. 2 has three layers consisting of an input layer with twelve inputs, a single hidden layer with sigmoidal activation functions consisting of fourteen neurons, and an output layer with two outputs. This paper considers neuroidentifier training which is carried out with deviation of the actual signals as inputs and outputs of the neural network.

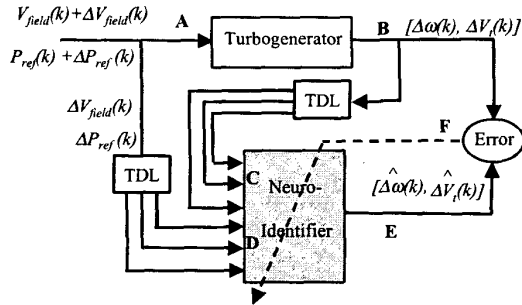

Figure 2: Neuroidentifier fed with delayed values of the inputs and outputs of the turbogenerator

The neuroidentifier inputs are the deviation in the actual power  $\Delta P_{ref}$  to the turbine, the deviation in the actual field voltage  $\Delta V_{field}$  to the exciter, the deviation in the actual terminal voltage  $\Delta V_t$  and the deviation in the actual speed  $\Delta \omega$  of the turbogenerator. These four NN inputs are also delayed by the sample period of 10 ms and, together with eight previously delayed values, form twelve inputs altogether to the neuroidentifier. For this set of neuroidentifier inputs, the neuroidentifier outputs are the estimated terminal voltage deviation  $\hat{\Delta V}_t$  and estimated speed deviation  $\hat{\Delta \omega}$  of the generator.

A sampling frequency of 100 Hz is chosen which is sufficiently fast for the neuroidentifier to reconstruct the speed and RMS terminal voltage signals from the sampled input signals. The number of neurons in the hidden layer of the neuroidentifier is determined empirically. The initial values of the neuroidentifier weights are set to small random values between -0.1 and +0.1, and the conventional backpropagation algorithm is used to update these weights. The differences between the respective actual outputs of the turbogenerator measured during the practical implementation phase and the estimated outputs from the neuroidentifier, form the error signals for the updating of weights in the neuroidentifier. A reasonable learning rate is determined by training the neuroidentifier and setting the learning rate parameter to achieve a compromise between the training time and the accuracy of the network. The flowchart for the

neuroidentifier implementation in both simulation and practical implementation studies is given in Fig. 3.

#### 4 Practical Implementation Results

Simulation studies of neuroidentification of turbogenerators described in this paper were carried out, prior to real time practical implementation in the laboratory, in a manner similar to that described in [8]. The simulation results are not shown to conserve space.

The neuroidentifiers are implemented on the Innovative Integration M67 card based on the TMS3206701 digital signal processor, operating at 160 MHz, hosted on a Pentium III 433 MHz personnel computer. The M67 card is equipped with eight differential A/D interfaces. The A/Ds have 12-bit resolution and a minimum throughput rate of 200 kHz.

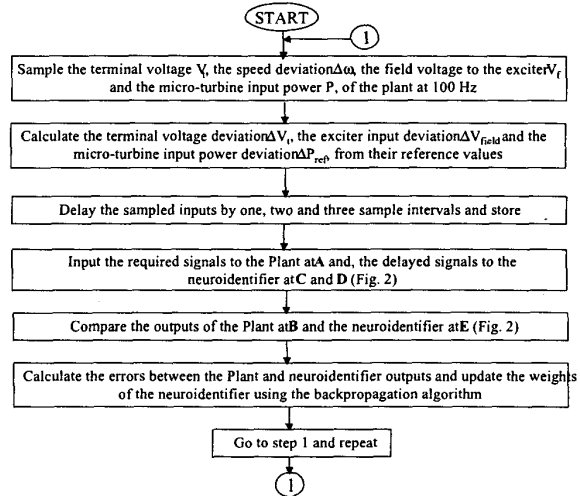

Figure 3: Flowchart for the neuroidentifier program implementation

Two sets of results are presented. The first set uses so-called forced training, which shows how well the neuroidentifiers are able to track changes as long as training continues while the system is forcefully perturbed by Pseudorandom Binary Signals (PRBS),  $\Delta V_{field}$  and  $\Delta P_{ref}$ . The second set of results uses unforced training or so-called natural training, where  $\Delta V_{field}$  and  $\Delta P_{ref}$  are both zero, and shows how well the neuroidentifiers continues to track generator outputs which are changing due to changes on the power system network.

#### 4.1 Forced Training

A constant field voltage  $V_{field}$  and a turbine power signal  $P_{ref}$  are applied to each of the generators at a particular steady state operating point. Then the neuroidentifiers are trained by adding pseudo-random binary signals  $\Delta V_{field}$  and  $\Delta P_{ref}$  to  $V_{field}$  and  $P_{ref}$  respectively. These random signals excite the full range of the dynamic response of the generators. The PRBS in Figs. 4 and 5 show  $\pm 5\%$  deviations in the steady state values of  $V_{field}$  and  $P_{ref}$  of generator G1 at an operating point,  $P_{ref1}=0.1$  p.u. and lagging power factor (pf) of 1. Similar training signals are applied simultaneously to the second generator, G2 ( $P_{ref1}=0.1$  p.u. and lagging pf = 1)

A learning gain of 0.3 is used for the backpropagation algorithm. The neuroidentifiers are only required to generalize one time step (10 ms) ahead, so no momentum term is used. The training errors are insignificant after only a few seconds of training.

Figs. 6 and 7 show the speed deviation and terminal voltage deviation respectively of generator G1 and neuroidentifier #1 during the first few seconds of training. They show that the neuroidentifier #1 is able to track the outputs of generator G1 within the first three seconds of training. The true outputs of the generators and the neuroidentifiers' estimated outputs are shown by solid and dashed lines respectively in all diagrams.

Figs. 8 and 9 show the speed deviation and terminal voltage deviation, respectively, of generator G2 and neuroidentifier #2. Once again, neuroidentifier #2 is able to track the outputs of generator G2 within the first three seconds of its training. All these results therefore show that the errors between the neuroidentifiers' outputs and generators' outputs are insignificant only after a few seconds of online training. These initial errors came about because all the neural networks started with random initial values of their weights. If the system is subsequently switched off and back on again, the weights start with already trained values and the errors are insignificant right from the start.

Figs. 6 to 9 prove that the neuroidentifiers have learned the dynamics of the generators, and the network, to which they are connected, with sufficient accuracy, based only on local information.

After 5 s of training, the operating points are changed to different values of  $P_{ref}$  and pfs at the machine terminals, by adjusting input power  $P_{ref}$  and field voltage  $V_{field}$  of the generators, and the training is continued. The results indicate (though not shown in the paper due to space constraints)

despite the changes in the operating points, the neuroidentifiers are able to track the outputs of the generators immediately.

The forced training of the neuroidentifiers with PRBS of the form of Figs. 4 and 5 is now terminated and from here the natural training, starting with weights obtained from the PRBS training.

#### 4.2 Natural Training

Two different tests are carried out in order to evaluate the performances of the neuroidentifiers for changes in the power system network configuration, after the forced training has stopped but the natural training continues. The first test is a stepwise addition of a lagging power factor shunt load ( $P = 0.84$  p.u. and 0.85 lagging pf) halfway between buses 2 and 5 by closing the switch S3 (Fig. 1), for the generators with operating points:  $P_{ref1,2} = 0.3$  p.u. and unity lagging pf. The speed deviation and the terminal voltage deviation of generator G2 are shown in Figs. 10 and 11 respectively. Similar good tracking results are seen with generator, G1.

The second test is carried out to simulate the effects of a loss of one of the parallel transmission lines between buses 1 and 4, by opening the switch S2 (Fig. 1), for the generators with operating points:  $P_{ref1,2} = 0.3$  p.u. and unity lagging pf. The speed deviation and the terminal voltage deviation of generator G2 are shown in Figs. 12 and 13 respectively. Similar good tracking results are seen with generator, G1.

All the above results of figures 10 to 13, show that the neuroidentifiers are able to track the terminal voltage and speed deviations of their respective generators with changes in the network configuration, implying that the forced training carried in section 4.1 with the PRBS was sufficient to excite all the possible dynamics of the generators.

#### 5 Conclusions

A multiple number of multi-layer feedforward neural networks have been successfully applied to identify multiple turbogenerators even when the power system network configuration and operating points changes. Experimental results indicate that the proposed scheme is potentially very promising for identifying highly nonlinear MIMO turbogenerators in the input-output representation form. Furthermore, it is important to emphasize that *no off-line training is necessary*. Such neural network models may first be used in a multi-machine power system plant simulator and eventually find a place in the control room, providing plant

operators and power system control engineers with enhanced understanding of the operation of the turbogenerators.

## 6 References

- [1] P.M.Anderson, A.A.Fouad, *Power System Control and Stability*, New York: IEEE Press, 1994, ISBN 0-7803-1029-2.
- [2] B.Adkins and R.G.Harley, *The General Theory of Alternating Current Machines*, London: Chapman and Hall, 1975, ISBN 0-412-15560-5.
- [3] Q.H.Wu and B.W.Hogg, "Adaptive Controller for a Turbogenerator System", *IEE Proceedings*, vol. 135, Pt D, no 1, 1988, pp 35-42.
- [4] Q.Lu and Y.Sun, "Nonlinear Stabilizing Control of Multimachine Systems," *IEEE Trans. Power System*, vol. 4, 1989, pp. 236-241.
- [5] Z.Qiu, J.F.Dorsey, J.Bond and J.D.McCalley, "Application of Robust Control to Sustained Oscillations in Power Systems" *IEEE Trans. Circuits System*, I, vol. 39, 1992, pp. 470-476.
- [6] G.K.Venayagamoorthy and R.G.Harley, "Implementation of an Adaptive Neural Network Identifier for Effective Control of Turbogenerators", *Proceedings of 1999 IEEE Budapest Power Tech Conference*, Hungary, BPT99-431-6.
- [7] G.K.Venayagamoorthy and R.G.Harley, "Experimental Studies with a Continually Online Trained Artificial Neural Network Controller for a Turbogenerator", *Proceedings of the International Joint Conference on Neural Networks, IJCNN 1999*, Washington D.C, USA, vol. 3, pp. 2158-2163.
- [8] G.K.Venayagamoorthy, R.G.Harley and D.C.Wunsch, "Adaptive Neural Network Identifiers for Effective Control of Turbogenerators in a Multimachine Power System", *Proceedings of the IEEE PES Winter Meeting*, Columbus, USA, January 2001.
- [9] D.J.Limebeer, R.G.Harley and S.M.Schuck, "Subsynchronous Resonance of Koeberg Turbogenerators and of a Laboratory Micro-alternator System", *Transactions of the South African Institute of Electrical Engineers*, November 1979, pp. 278-297.
- [10] K.S.Narendra and K.Parthasarathy, "Identification and Control of Dynamical Systems using Neural Networks", *IEEE Trans. On Neural Networks*, vol.1, no. 1, Mar. 1990, pp. 4-27.

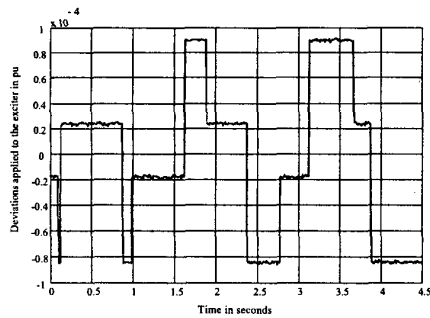

Figure 4: Forced PRBS training signal  $\Delta V_{field1}$  applied to the generator G1

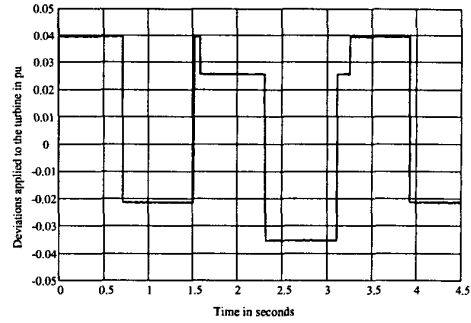

Figure 5: Forced PRBS training signal  $\Delta P_{ref1}$  applied to the generator G1

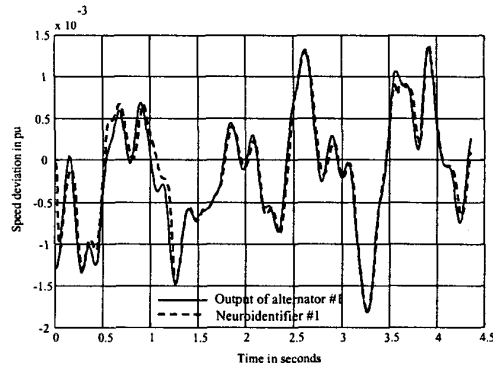

Figure 6: Speed deviation of the generator G1 and the neuroidentifier for  $\pm 5\%$  deviations in  $V_{field1}$  and  $P_{ref1}$

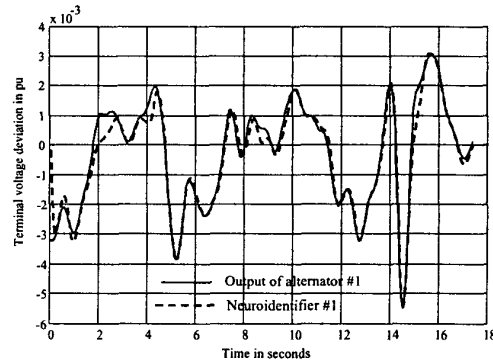
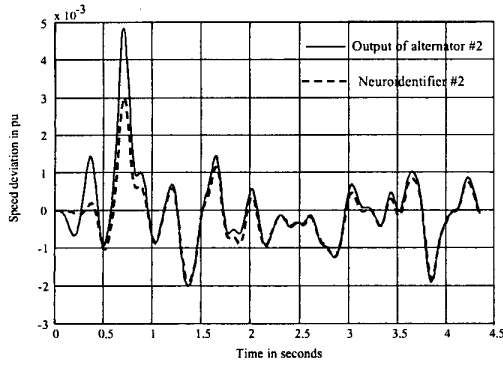
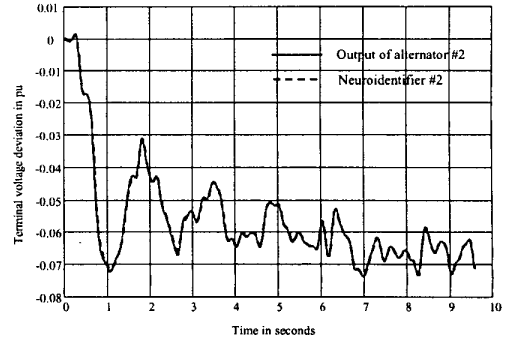

Figure 7: Terminal voltage deviation of the generator G1 and the neuroidentifier for  $\pm 5\%$  deviations in  $V_{field1}$  and  $P_{ref1}$



**Figure 8:** Speed deviation of the generator G2 and the neuroidentifier for  $\pm 5\%$  deviations in  $V_{field2}$  and  $P_{ref2}$



**Figure 11:** Terminal voltage deviation of the generator G1 and the neuroidentifier for a stepwise load addition with switch S1 now closed

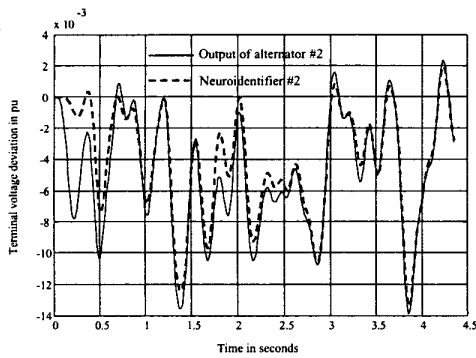

**Figure 9:** Terminal voltage deviation of the generator G2 and the neuroidentifier for  $\pm 5\%$  deviations in  $V_{field2}$  and  $P_{ref2}$

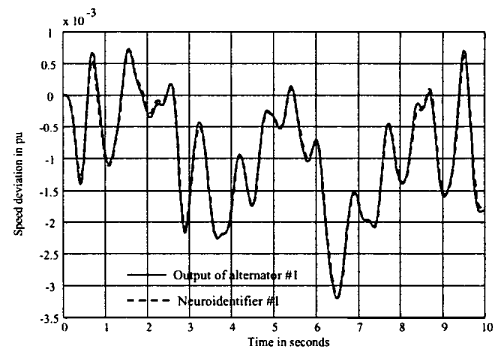

**Figure 12:** Speed deviation of the generator G1 and the neuroidentifier for a line loss with switch S2 now opened

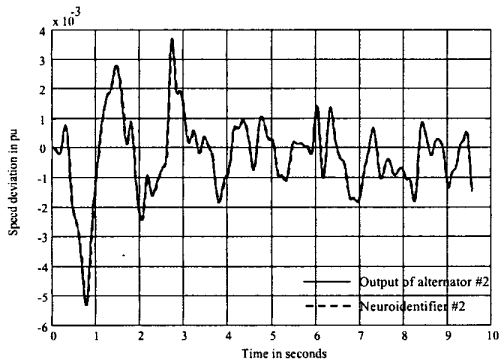

**Figure 10:** Speed deviation of the generator G1 and the neuroidentifier for a stepwise load addition with switch S1 now closed

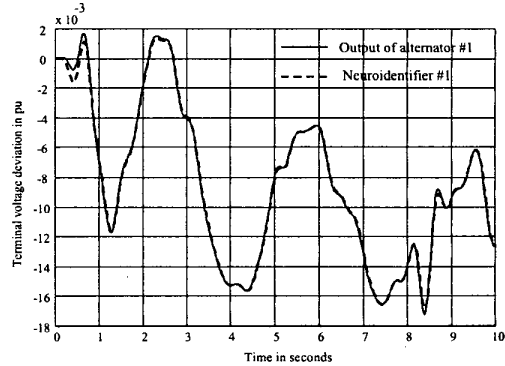

**Figure 13:** Terminal voltage deviation of the generator G1 and the neuroidentifier for a line loss with switch S2 now opened